

# Quick user guide

Revision 2.5

---

## Overview

Before operating the PIRA film processor please read and understand the following instructions in full.

Failure to do so may lead to damage to the device or incorrectly developed film.

For further assistance, questions or comments, click on the Contact page in the website and we'll get back to you as soon as possible.

# Table of contents

---

## 1 Package contents

1.1 Inventory and description .....	2
-------------------------------------	---

## 2 Operation

2.1 Menu navigation .....	4
2.2 Program setup .....	5
- Setting developer time .....	6
- Chemical reuse compensation .....	6
- Intermittent or continuous agitation .....	7
- Custom program .....	9
2.3 Loading film and reels .....	10
2.4 Running a program .....	12
- Heater function .....	13
- Reset developed rolls .....	13
- Testing reel motion .....	14
- Time compensation diagram .....	15
2.5 Using the extra magnets .....	17

## 3 Additional settings and maintenance

3.1 Temperature calibration .....	18
3.2 Alarm type and lights off .....	19
3.3 Acceleration .....	19
3.4 Push/pull multiplier .....	20
3.5 Troubleshooting .....	21

# 1 Package contents

---

## 1.1 Inventory and description

### A. PIRA - Darkroom Helper device

### B. Retaining clamp

Place at the top of the center column to hold the reels in place.

### C. AC/DC Wall adapter

### D. Tank liner

Reduces friction and protects the inside of the tank from scratches. Use only one at a time.

### E. Centering discs x2

Two sizes included for the 2-reel and the 3-reel (or 5-reel) tanks. It sits in-between the magnetic disc and the reels. Keeps the magnetic disc centered at all times.

### F. Magnetic disc

Goes inside the tank, transmits motion to the reels.

### G. Set of six magnets

Carefully place inside the machine on the rotating base to increase magnetic strength for the 5-reel tank.

### H. Magnet removal tool

Extract magnets by sliding them sideways first, then lifting up.



**HINT:** You can reach us via the Contact link on the website for spare parts in case they're missing or due to wear, loss, etc.

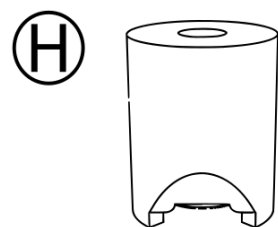
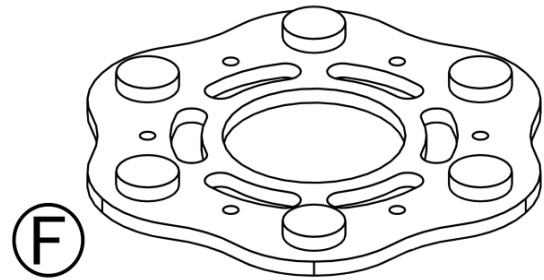
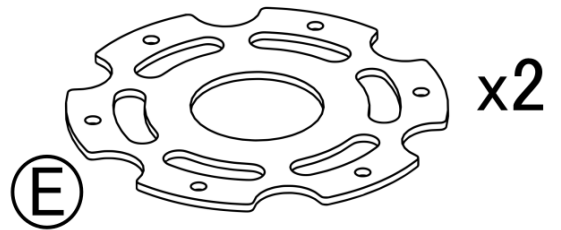
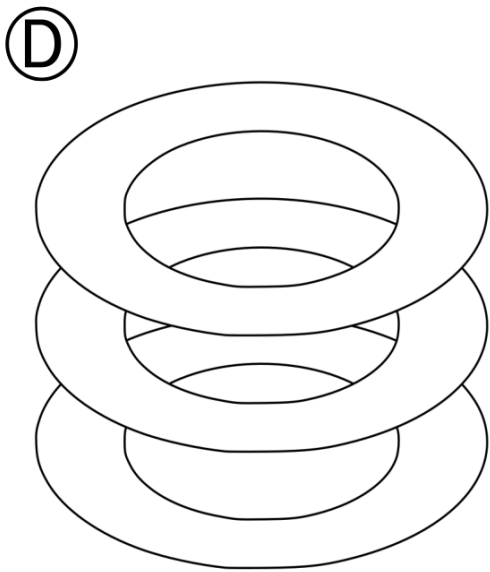
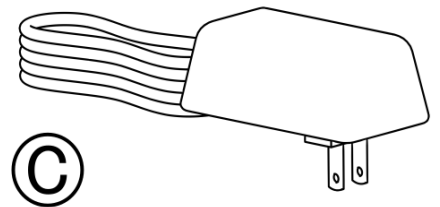
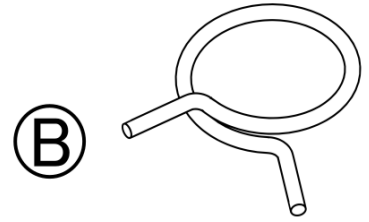
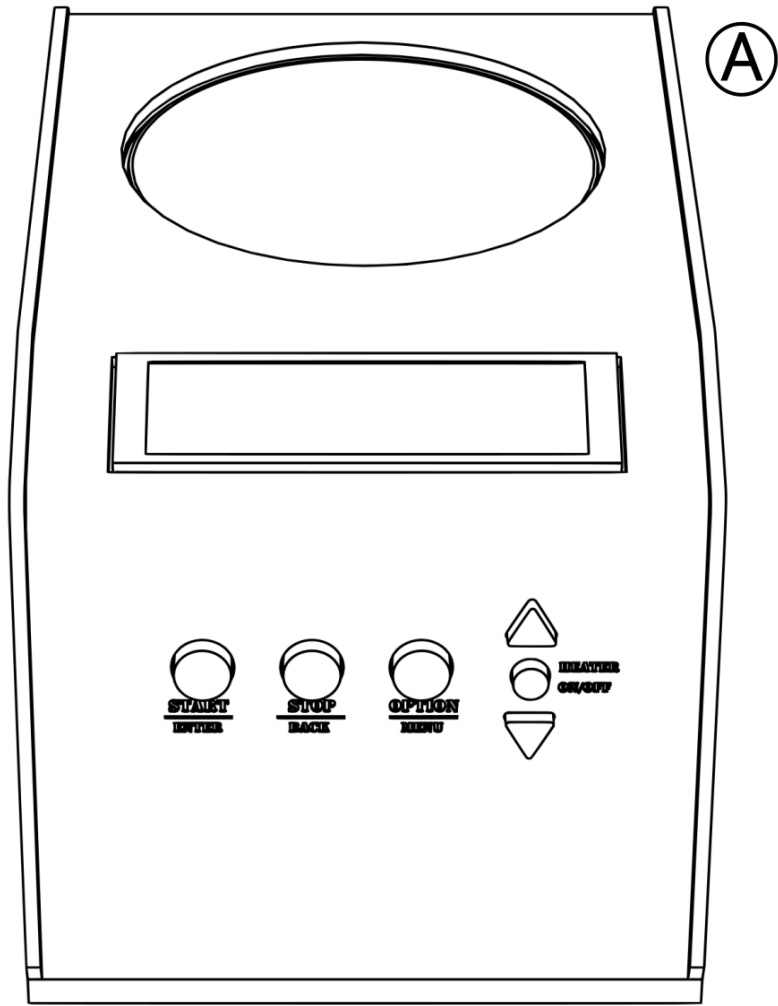

# 2 Operation

## 2.1 Menu navigation

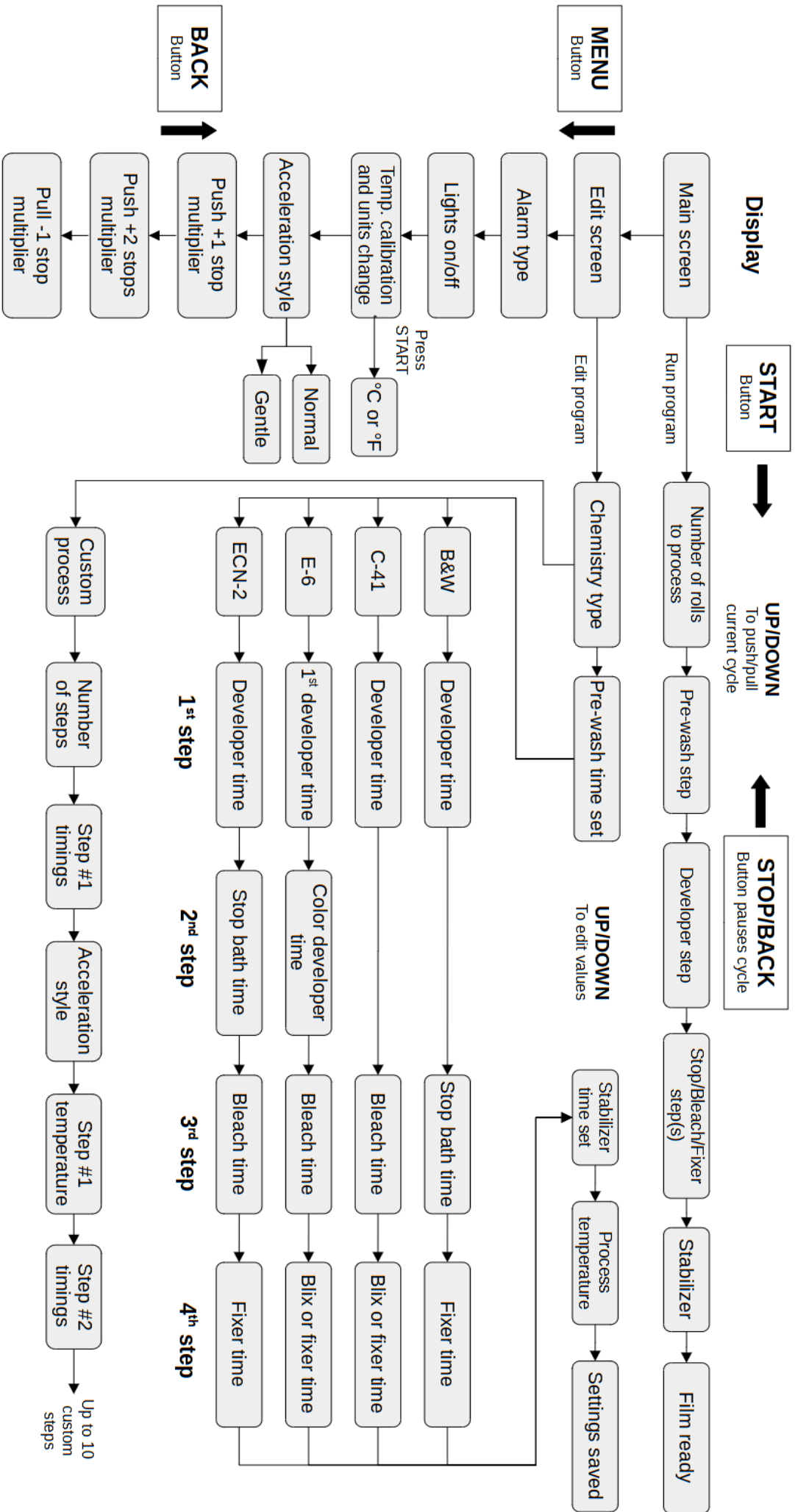

## 2.2 Program setup

For programming a new routine, navigate with the OPTION button until the screen displays the "Press enter to edit" message:

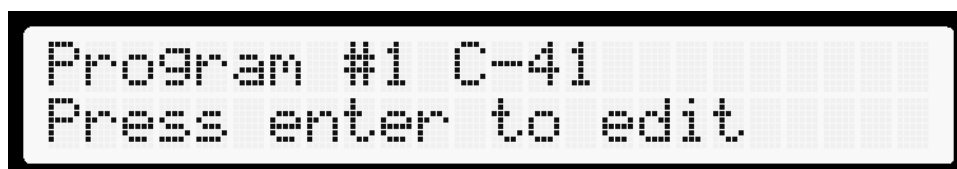

Program #1 C-41  
Press enter to edit

Here you can save up to eight different chemistry types, each with its own times and number of rolls developed (except for custom processes). Pressing UP and DOWN buttons changes the selected program.

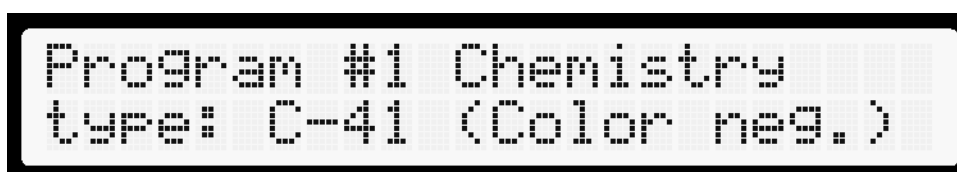

Program #1 Chemistry  
type: C-41 (Color neg.)

Next you can select which chemistry to use: Black and White, C-41 (color negative), E-6 (color slide), ECN-2 (movie film) or custom.

The type of film selected will determine the nomenclature and number of steps.

Example: For E-6 you will be prompted to input 1st developer and 2nd developer times, B&W and ECN-2 will have stop bath times, and so on.



Pre-wash time:  
In 0s

Pre-wash is a simple timer to warm up the inside of the film tank. Set to 0 if this step is not needed.

Then set the developer time according to manufacturer's instructions with the UP/DOWN buttons, then press Enter.

```
Developer time:
3m 30s (OPT toggles m/s)
```



**HINT:** Press OPTION to toggle between minutes and seconds selection.

```
Add time per roll: 3%
Press: UP->% Down->time
```

On this screen you can tell the machine how much to compensate for every roll that has already been developed with this specific chemistry.

Pressing the UP button will show you a percentage amount, while pressing the DOWN key will set the value in seconds per roll.

Example: 3% with 5 rolls previously developed and base developer time of 3 minutes, will result in a time of: 3m 27s for the 6<sup>th</sup> roll.

This is automatically calculated at the beginning of each processing cycle.

This calculation only affects the Developer, not the rest of the steps (Blix, Stop bath, etc) Setting this value to 0 deactivates the automatic compensation.

Next, set the time for the initial agitation:

```
Agitate the first 15s  
(Press OPT change nodes)
```

OPTION changes to continuous rolling mode, where the motor doesn't stop until the timer has ended:

```
Continuous rolling  
(Press OPT change nodes)
```

For normal intermittent agitation the next screen will allow you to change how long after (and how many times) to agitate the tank until the step is finished:

```
Every 30s thereafter do:  
Agitate 3 times (6s)
```



**HINT:** Each agitation lasts for 2 seconds in “normal” acceleration and 4 seconds in the “gentle” setting.

If continuous rolling was selected then you will be prompted to set the motor speed (1 to 10) and the time between changes of spin direction:

```
Reverse spin every: 10s  
Motor speed: 5
```



**HINT:** Numbers 1 to 10 correspond with the motor power setting. Speeds can range from 20rpm up to 160rpm depending on the load (tank size and liquid volume). Recommended values are between 3 and 7.

Subsequent settings will change depending on the chemistry type, but they're all self explanatory. In this case the chemistry chosen was C-41, so the machine now asks if we want to do bleach and fixer in a single step (Blix) or we want to keep them separate (use UP/DOWN arrow to change).

```
Bleach/fix:
Single step (Blix)
```

Press Enter and you will be asked to input time and number of agitations again, just like in the previous developer step.

The last timer setting is for the stabilizer or wetting agent:

```
Stabilizer/wetting agent
3m 0s
```

And finally, set the process temperature according to the manufacturers' instructions. Please note that the ultimate accuracy will be determined by your external heating method (example: sous vide water bath), the machine's internal heater is only used to hold the temperature and compensate for any heat lost in the process: If your temperature is too low to begin with, the heater will not bring it back up.

```
Process temperature:
39.0°C
```



**NOTE:** In ECN-2 you will be prompted to input two temperatures, one for the developer and one for the rest of the steps.

```
Settings saved
successfully
```

Confirmation screen once the program has been saved into memory.

### *Custom program*

Similarly if you want to create your own custom developing process you can do so by selecting “Custom steps” early in the Chemistry type screen:

```
Program #1 Chemistry
type: Custom steps
```

Press enter to set the total number of steps (maximum of 10), then input the following data for each one of them:

- Time
- Acceleration type
- Agitations and duration
- Temperature

Continue until you see the message confirming the settings have been saved.

## 2.3 Loading film and reels

The process of preparing the film when using the Pira film processor is not much different than working with a regular Paterson tank.

First slide the magnetic disc at the bottom of the tank's center column/tube.

This can be done in daylight prior to inserting the reels:

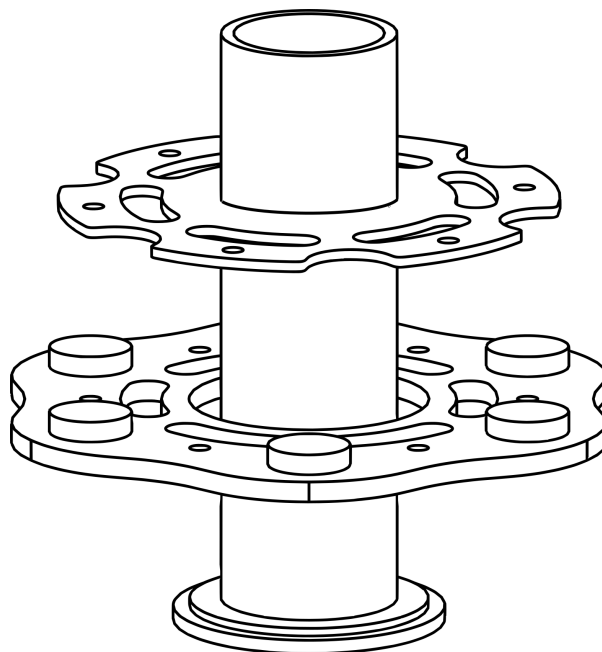

The disc assembly is comprised of two parts, the largest one where the magnets are located and a thinner transparent "Centering disc" that holds it to the core.

Two different sizes are provided for the clear disc, this is due to the variation in diameter size in Paterson tanks' columns. Make sure to use the correct fit, and do not apply excessive force to push the disc all the way down, otherwise it will be impossible to remove without breaking.

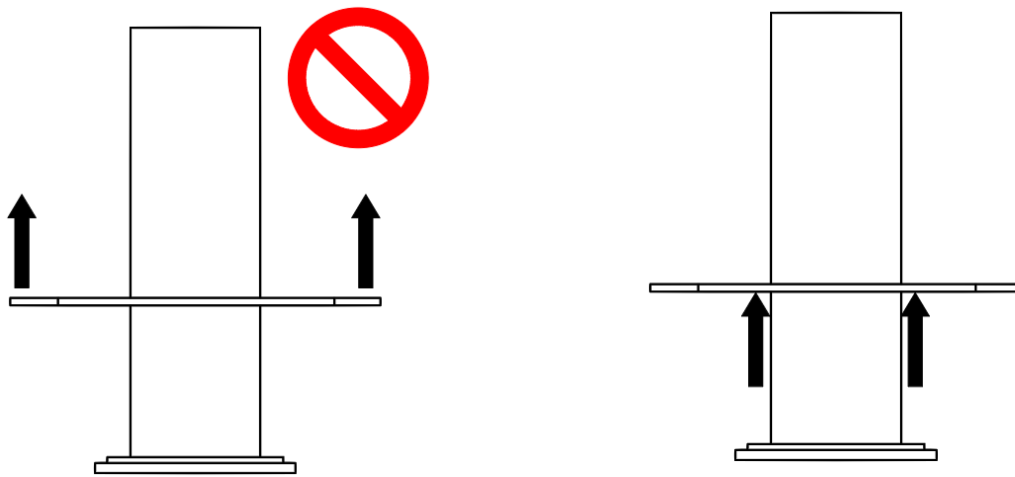

**HINT:** To remove this disc do not pull on the edges as it can bend and dig into the column. Instead use your fingers to push it out from the center.

If necessary the hole in the disc can be slightly enlarged with a coarse grit sandpaper, a file or similar grinding material.

A steel retaining clamp is also provided as an extra precaution to keep the reels from sliding up in the column, especially during rinsing maneuvers or during the strong agitation needed to remove remjet in the ECN-2 process.

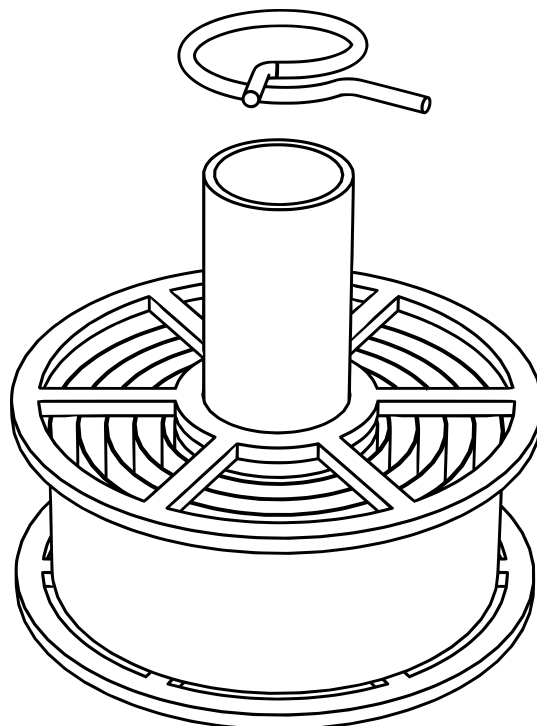

This clamp it's not necessary in the 2-reel tank, but recommended in the 3-reel tank and when processing a single reel.

Finally, a small disc of low friction material is included which can be placed at the bottom of the tank prior to loading the film:

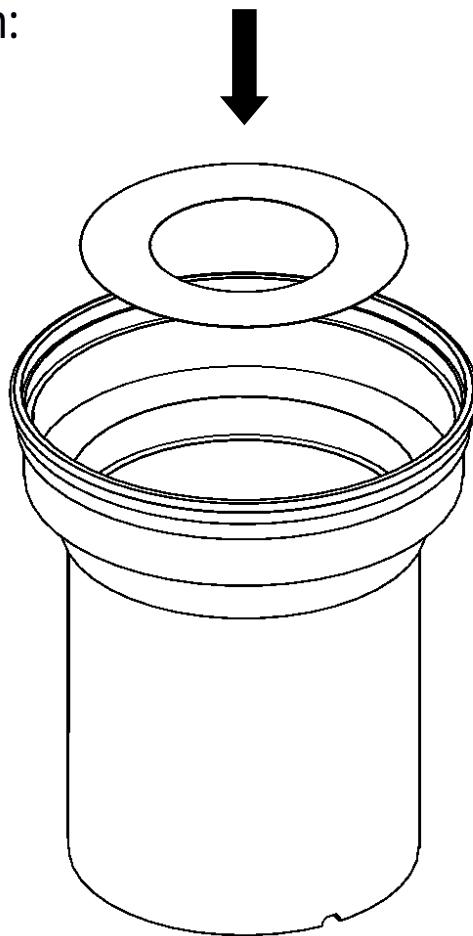

Its use is not 100% necessary but it's included as a precaution to reduce the friction and prevent scratching the bottom of the tank.

## 2.4 Running a program

Once the reels are inside and the light-proof lid is secured, you can proceed to place the tank inside the Darkroom Helper.



**HINT:** Line up the three notches in the Paterson tank with the tabs at the base of the unit. This prevents the tank from spinning and sets the correct height for the magnets to work.

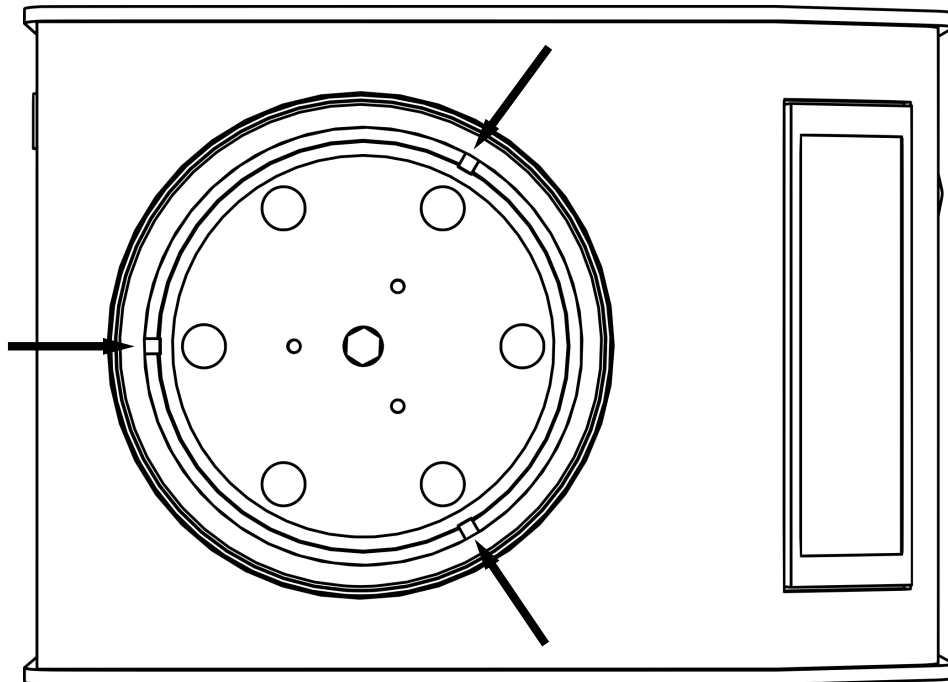

Now switch on the HEATER button if your process needs temperature control (color films). The heater button light will start blinking and turn solid once the sensor reaches the target temperature. After that wait an additional 10 minutes to let the inside of the machine and tank warm up uniformly.



**HINT:** While the machine is heating up you can begin to warm up your chemicals externally with a sous vide water bath.

Once everything is up to temperature, press the Start button in the main screen to begin the developing cycle.



You will be asked to input the number of rolls to process. To clear the number of previously developed rolls set to 0 then press Start/Enter.

```
C-41 Rolls to Process: 2  
(Set 0 to reset)
```

The next screen will prompt to add water in order to begin the pre-wash step.

Optional: **Press the UP or DOWN buttons to test the motor movement.** Confirm that the column is rotating by inserting the swizzle stick and see if it spins. Do not spin the motor with the magnets in place and a dry tank.



**HINT:** If the core is not spinning or there's a juddering motion, then the tank is likely not sitting all the way to the bottom of the machine. Rotate the tank until the three notches at the bottom line up and it drops into place.

```
Add water, Press Start  
(UP/down to test motion)
```

Press the Start button to begin countdown.

```
Pre-wash  
Waiting... On 30s
```

Once finished the machine will calculate the developer time according to the following settings:

- Additional time per roll
- Push or pull multipliers

Original developer  
time set by user

3m 30s

3m 30s equals 210  
seconds

+

Previously developed  
rolls compensation

Example with two  
previously  
processed rolls

Add time Per roll: 2%

=

2% x 2 rolls = 4%  
210 x 1.04 = 214s

+

Push or pull  
multiplier

Example with  
push +1 stop

+1 stop: x1.30 time

=

214 x 1.3 = 278s



Actual run time for  
developer step

4m 38s



**NOTE:** In the previous example both time compensation due to chemical reuse and push multiplier are shown, however it is recommended that push processing is only done with fresh chemicals to ensure consistency, as the strength on used developer can vary greatly depending on storage conditions.

You can quickly adjust the time according to the previously set +1, +2 and -1 stops multipliers by pressing the Up/Down buttons.

The total will be shown prior to starting the timer:



Cycle time: 4m 38s  
Push/pull: +1 stop

If the time shown is correct then pour in the chemicals and immediately press START to begin the agitation procedure.



Developer  
Agitating... 4m 30s

Next follow the on screen instructions for the remaining steps until the full cycle is complete:



Empty tank, then add  
Blix



Wash thoroughly then add  
stabilizer/wetting agent



Film ready

## 2.5 Using the extra magnets

The PIRA film processor includes six spare magnets that can be used to improve magnetic strength and help maintain the reels “coupled” with the rotating base.

When there’s a heavier load in the tank for example: 5x35mm reels, or 6 sheets of 4x5 film using a third-party adapter, it’s possible that the reels skip rotation and stay stationary instead of spinning. This is evident due to a knocking noise heard when the motor is running.

If you notice this skipping/knocking sound, **carefully** add the included magnets inside the machine one at a time in one of the following configurations:

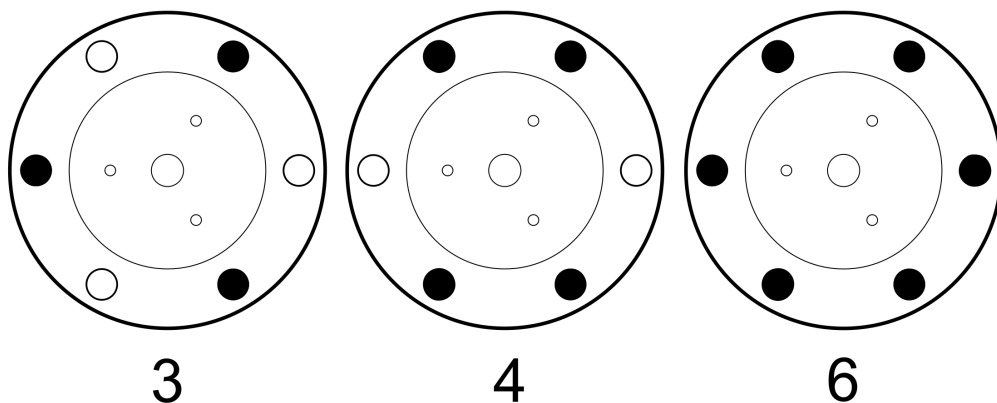

**HINT:** To remove use the included removal tool. Slide towards the center, then lift once the magnet is clear. Do not apply excessive downward force to the rotating base.

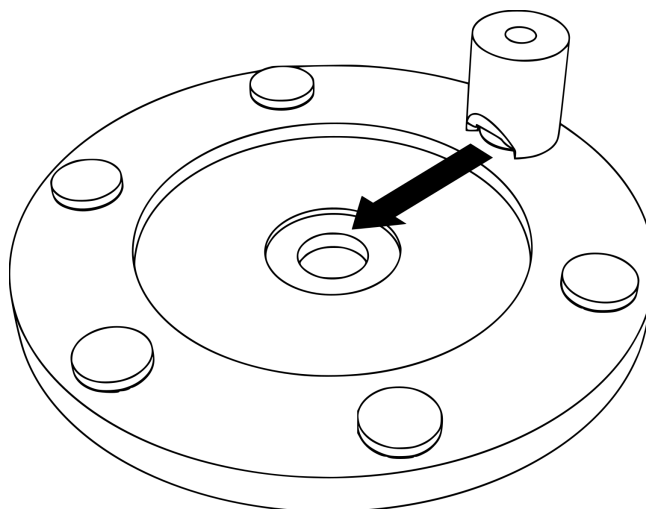

## 3 Additional settings and maintenance

---

### 3.1 Temperature calibration

Normally the temperature at the heating sleeve (as measured by the machine's sensor) will be slightly lower than the actual temperature of the liquids inside the tank. By default the device will have a +2°C offset.

However, the user has the ability to change this offset. In order to check if the temperature is dropping out of the manufacturer's recommended range, take a measurement with a thermometer in the center of the tank at the beginning and the end of the developer cycle.

If the temperature drops more than desired, then navigate to the following menu screen by pressing the OPTION button and adjust to a higher offset with the UP/DOWN buttons:



```
Temperature units: C
Offset: +2 C
```

Important: If the base temperature is too high or low to begin with, the external water bath will need adjustment instead.



**HINT:** Press START/ENTER to change between °C and °F. Please note that although Fahrenheit conversion is provided for convenience, the internal readings and calculations are still done in Celsius.

### 3.2 Alarm type and lights off

The machine will beep and flash the LCD screen at the end of each step. In case you don't want any audible alarm it can be switched off here:



Alarm type:  
Light + buzzer

With the Up/Down buttons choose between "Light only" or "Light + buzzer"

Pressing OPTION again will bring the following menu



Switch light on/off:  
Press enter

Press START/ENTER and it will switch off the LCD backlight and heater button light (if heater is on). This is useful in darkrooms when loading reels, as it allows the machine and heater to remain on, but will not emit any light.

### 3.3 Motor acceleration

Here you can change the rate of acceleration in the reels when they begin to rotate.



Acceleration: Normal  
Press Start to test

“Normal” will switch on the motor immediately and start spinning at maximum speed, whereas “Gentle” will slowly ramp the speed up and down.

This affects all movements across all steps (developer, stop bath, blix, etc) for the standard chemical types: B&W, C41, E6, ECN2. Only when using a custom process this can be changed individually for each step.

This feature is useful when developing with non-Paterson accessories, for example Hewes reels and 4x5 sheet film holders where the film might get easily dislodged with rapid alternating motion.



**NOTE:** In the “Gentle” setting each agitation lasts twice as long: An instruction to “Agitate 2 times” would last 8 seconds in Gentle acceleration and 4 seconds in Normal.

### 3.4 Push/pull multipliers

The machine can be programmed with three different time multipliers that can be called upon the start of a developing cycle.

This way it’s not necessary to edit the complete program for one-off push or pull processing.

```
Push/pull timings  
+1 stop: x1.30 time
```

```
Push/pull timings  
+2 stops: x1.75 time
```

```
Push/pull timings  
-1 stop: x0.74 time
```

### 3.3 Troubleshooting

*The reels are not spinning when the Developing step begins.*

When the “UP/DOWN to test motion” screen is shown (access by pressing START button two times from main screen). Press UP or DOWN keys and check if the motor is making any noise.

Is the motor running during the test?

**YES**

Ensure that the tank is sitting all the way to the bottom, rotate slightly until the three notches in the tank line up with the tabs inside the machine’s base.

**YES**

Double check that the current active program has a time set for the “Agitate for the first xx” instruction. Navigate to the edit screen and press START/ENTER to edit the program.

**YES**

If you have “Continuous rolling” mode active for the agitation, set the speed at a higher value (range is from 1 to 10) as the motor might be stalling.

**NO**

Possible hardware fault, please contact support.

*There’s a loud knocking sound when the motor spins*

If the tank is properly seated in the base, then you might need to add extra magnets to prevent skipping. Refer to page 17 for more details.

*The centering disc is too small or large for the Paterson tank center column.*

If the clear disc feels too tight when trying to push it all the way to the bottom of the column, it can easily be enlarged by using some sandpaper, file or other grinding material and sanding the hole in the disc until it slides in without too much effort.

In case the disc is too loose the machine should still work, you'll just need to be careful when handling the magnetic disc in the dark so that it stays centered when sliding in the reels.

Contact support if you require any additional discs.

*I can't remove the centering disc from the Paterson tank's center column.*

When pulling out the small disc DO NOT grab from the edges, example:

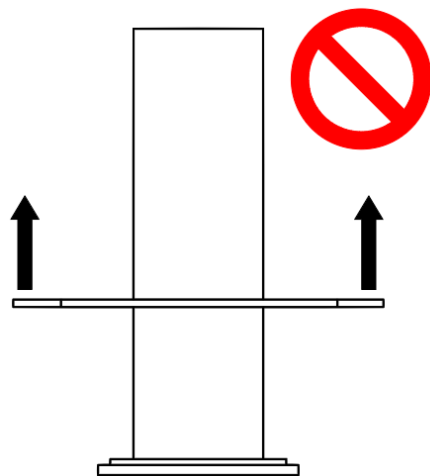

This will bend the plastic piece and it will grab tighter on the column.

Instead, use the magnetic disc to push it out from the bottom, this will keep it flat:

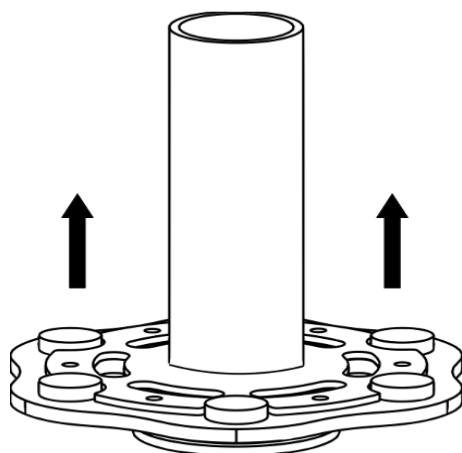

If the magnetic disc isn't present then push from the center with your fingers, also adding some water or soap will help to lubricate.

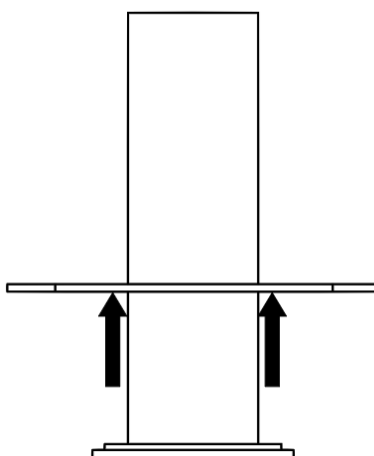

For the next developing session use the correct size disc or sand down the hole in the center to make it slightly larger.

*How do I clean the magnetic disc and/or the device in case of spills?*

The magnetic disc should be rinsed with cold water only, do not clean in a dishwasher and do not scrub excessively hard on the magnets as you might risk breaking them.

For cleaning the device, any damp cloth should be sufficient, do not spray liquids or submerge the machine.

*The temperature reading is jumping a little bit, it doesn't seem to stay exactly on target?*

It's completely normal for the temperature picked up by the sensor to jump by roughly 1 degree once it has reached the set value.

All the layers between the sensor and the contents of the tank, as well as the thermal mass of the heating sleeve and the chemicals, average-out these small variations over time, so this behavior does not affect normal operation.

Link to website:



<https://darkroomhelper.pira.mx/>

